

# Counterfeit Detection in Supply Chains



Nina Oertel

# Tracking



Serialized items

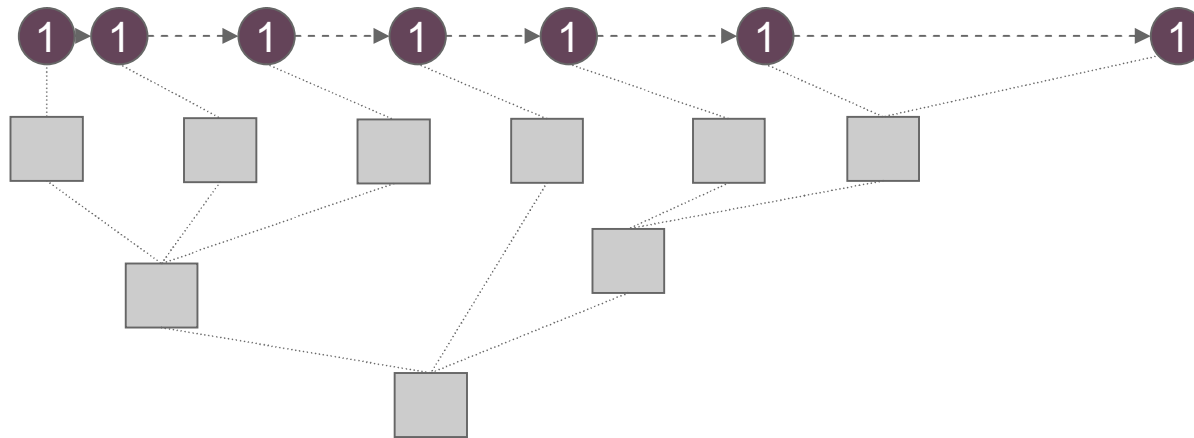
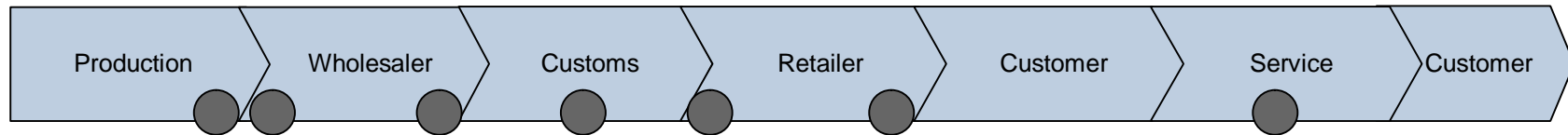
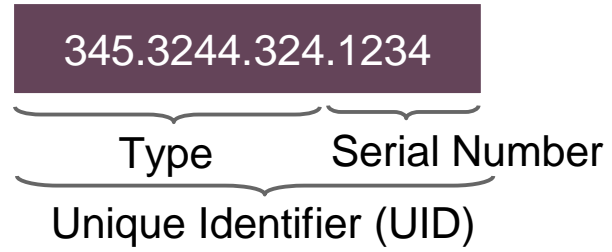

Tracking infrastructure

# Types of Counterfeit Detection Approaches

Decision taken by the user:

- Evaluation of individual item histories
- Visualization

Automated decision:

- Plausibility checks with pre-configured rules
- Automated learning of decision criteria

# User Decision - Single Item History



Product Verification Infrastructure  
Project website

**SAP RESEARCH**

Service Center

**Type**

**Tag Number** 00000000BE562E8A



**Serial Number** 2384580339MX

**Warranty** Sell Warranty: Until 01.06.2010

Step	Location	Date
SALE	FRANCE_BOUTIQUE_A	01.06.08 - 12:45
DISTRIBUTION	SWITZERLAND_DC_B	28.10.07 - 08:00
PRODUCTION	MANUFACTURER_B	26.02.07 - 08:15

SKU	Final Result	Status	Tag Number	Serial Number	History	Photo
WS1008Q3						
				<input type="button" value="Yes"/>	<input type="button" value="Yes"/>	<input type="button" value="Yes"/>
				<input type="button" value="No"/>	<input type="button" value="No"/>	<input type="button" value="No"/>

General comment

Home

---

Logout

---

DB Setup for Richemont

---

Packing

Unpacking

Bulk Check

---

Point of Sales

Service Center

# User Decision - Visualization

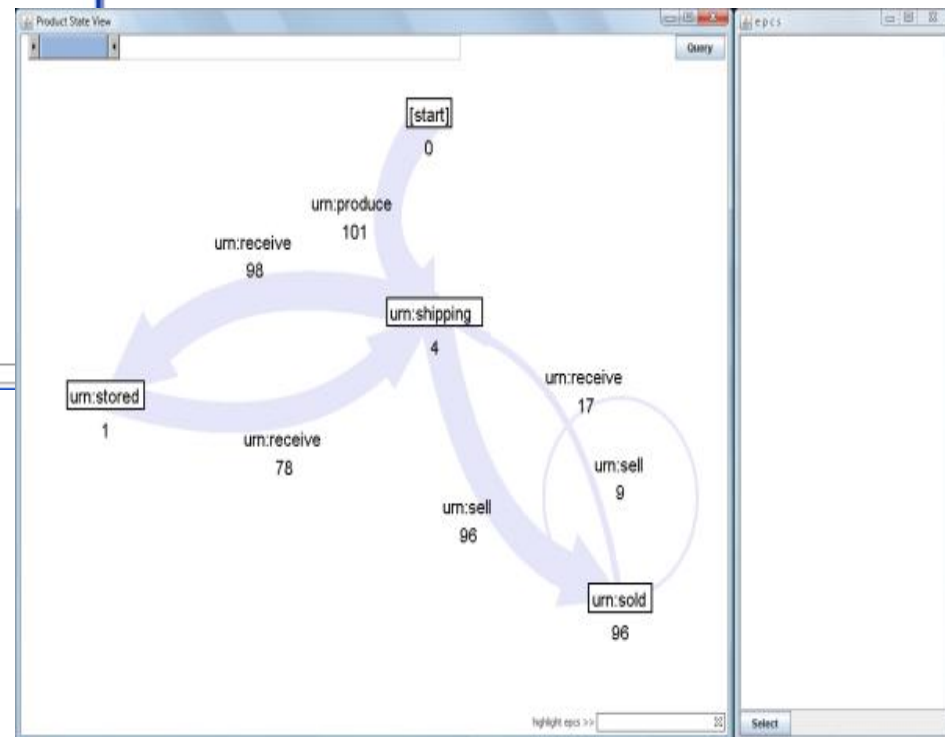
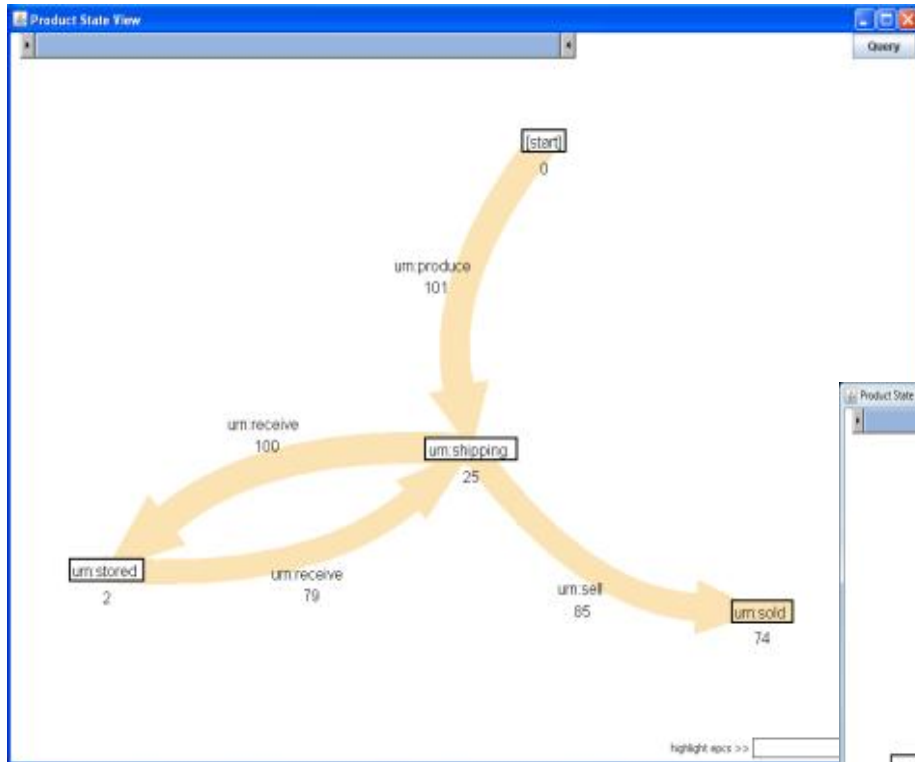

# User Decision - Visualization

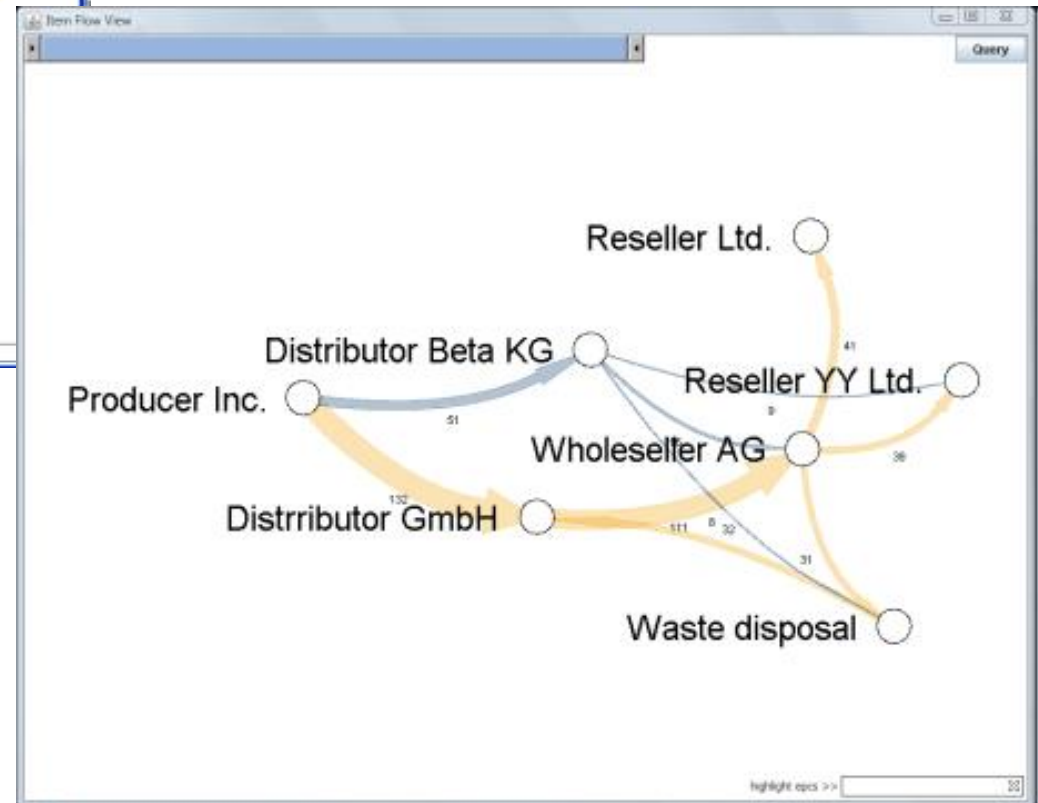
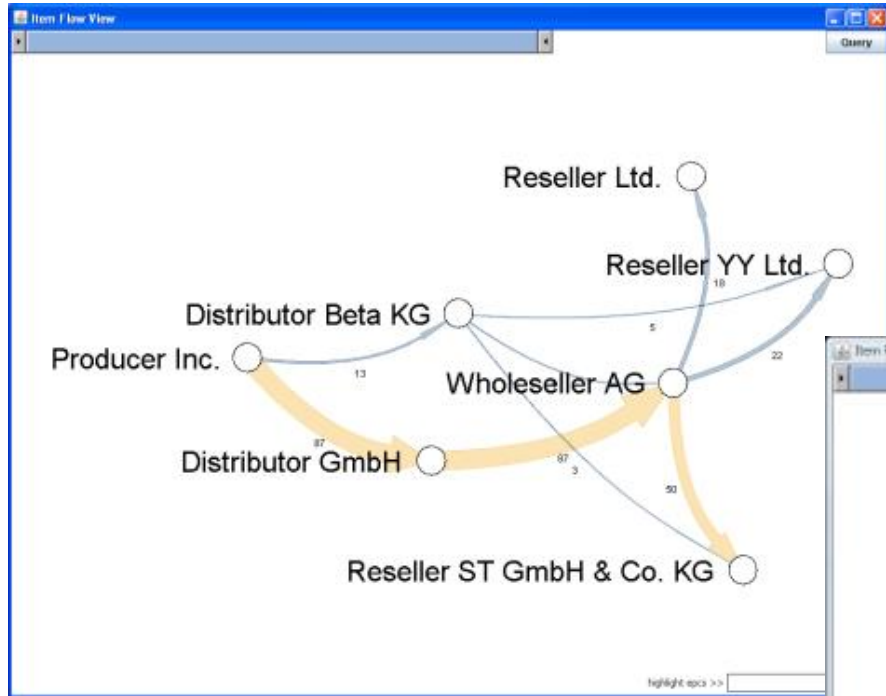

# Automated Decision - Rules

Specification of plausibility rules that every item history must match

- Each item may only be sold once
- But: An item may be returned and sold again
- Each item that is received must have been shipped
- But: RFID readers need not be available at every supplier
- If an item was delivered to supplier A, B or C, there must be a shipping event, otherwise no shipping event is allowed
- But: Only some shipping gates of supplier A might be equipped with RFID readers; at some gates there might be an additional quality control
- ...

Rules must be precise to have a high detection accuracy and low false positive rate

Precision means specification and maintenance effort

# Learning of Decision Criteria

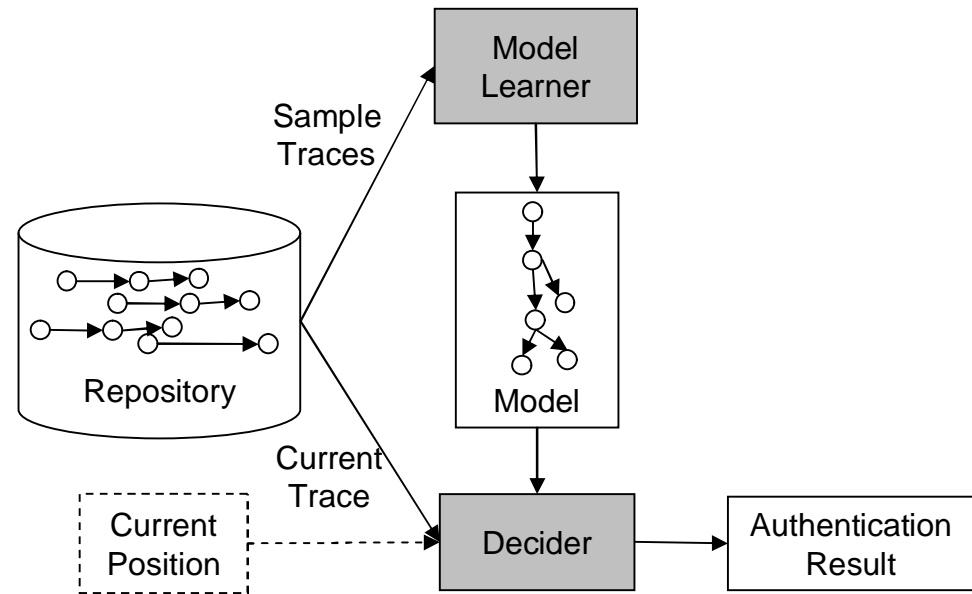
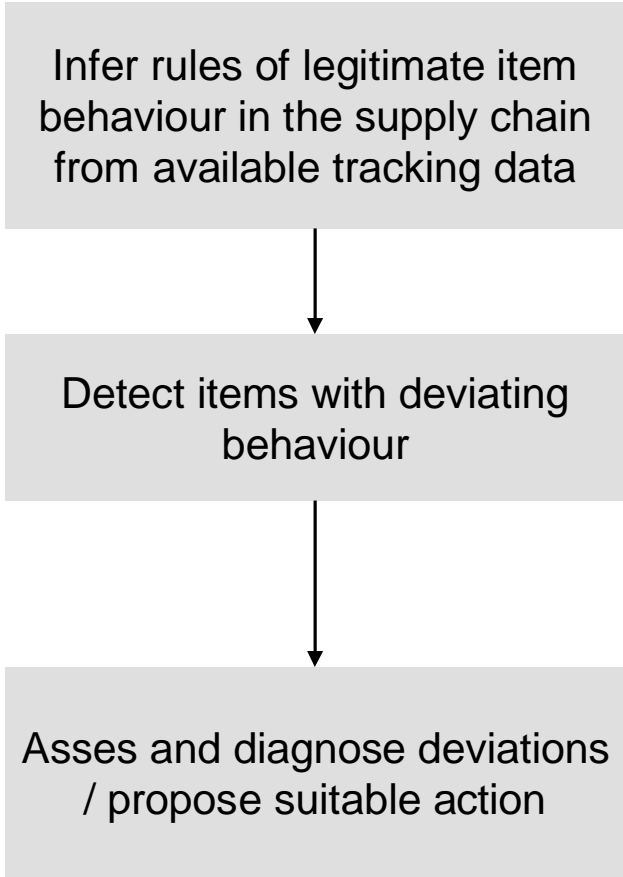

# Supply Chain Model

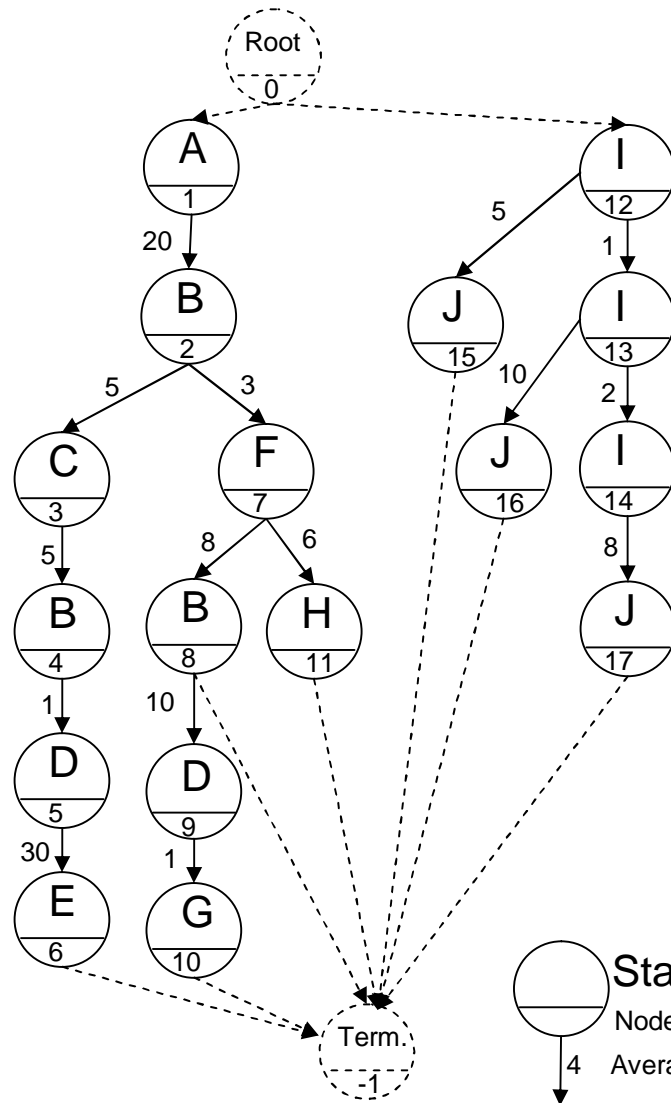

Node	Station
1	A
2	B
3	C
4	B
5	D
...	...

Station	Location	Step
A	Lyon Plant A	Production
B	Paris DC A	Shipping
C	Paris Shop A	Receiving
D	London Outlet A	Receiving
E	London Outlet A	Sale
...	...	...

Transition	Transition	Min.	Max.	Average
Source	Target	Time	Time	Time
1	2	5	30	20
2	3	1	20	5
2	7	2	10	3
3	4	2	7	5
4	5	0,5	5	1
...	...	...	...	...

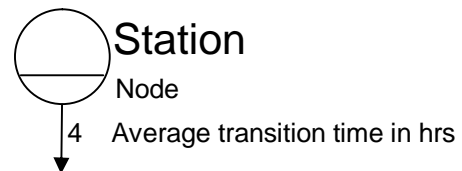

# Counterfeit Detection

Reported Trace:  
(A,B,C,E,G,H)

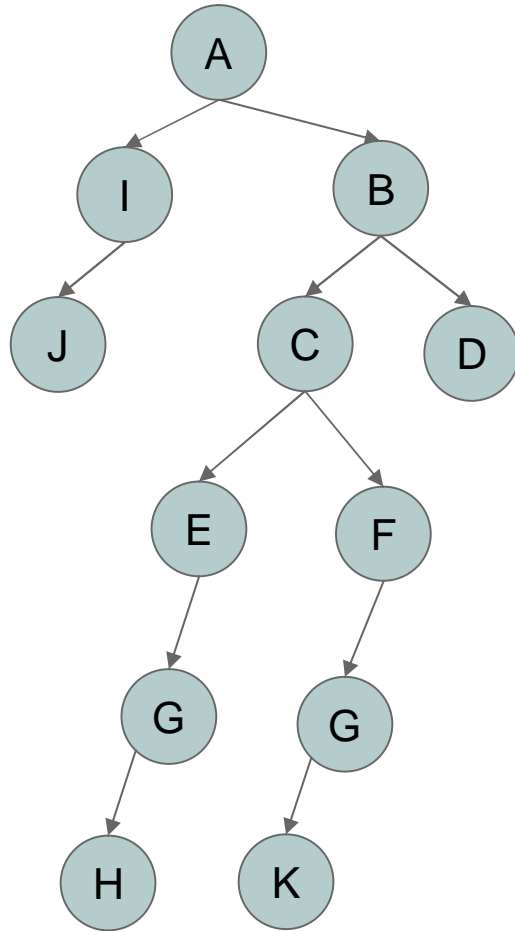

Genuine Item

Reported Trace:  
(G,H)

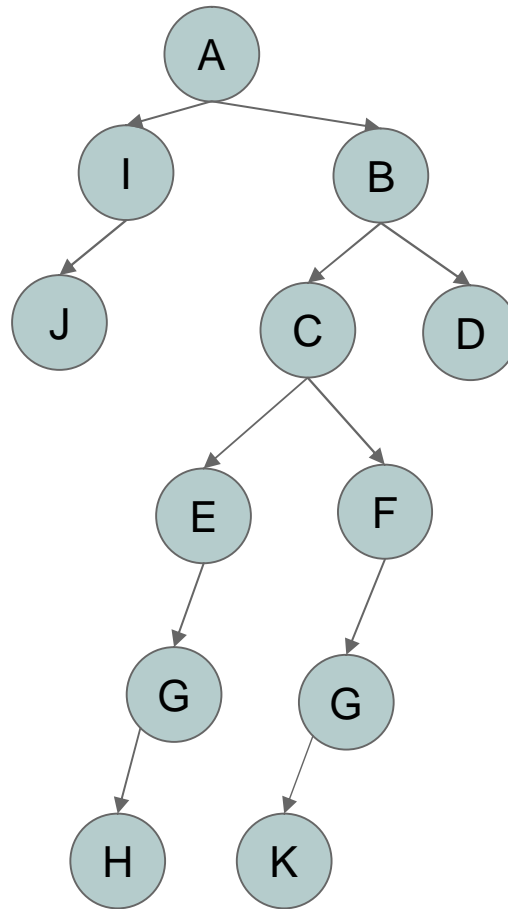

Guessing

Reported Trace:  
(A,I,B,C,J,E,G,H)

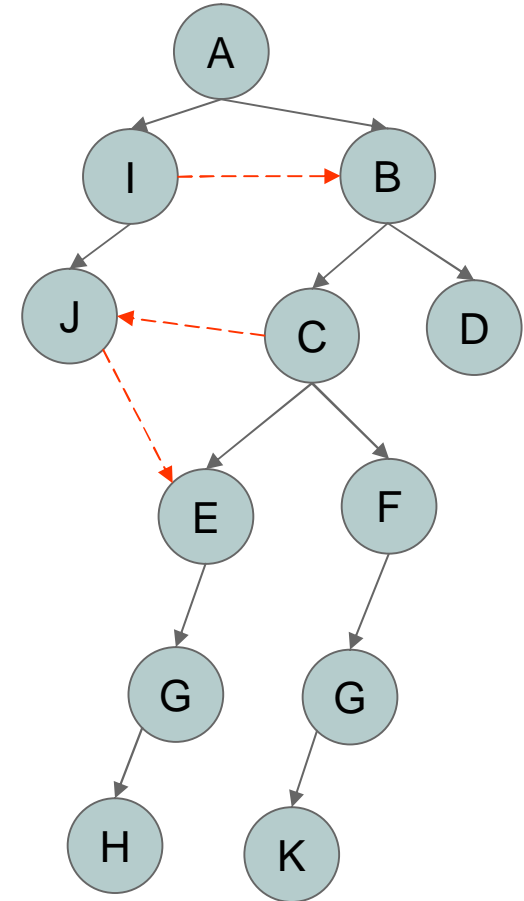

2 Copies



# Simulation Results

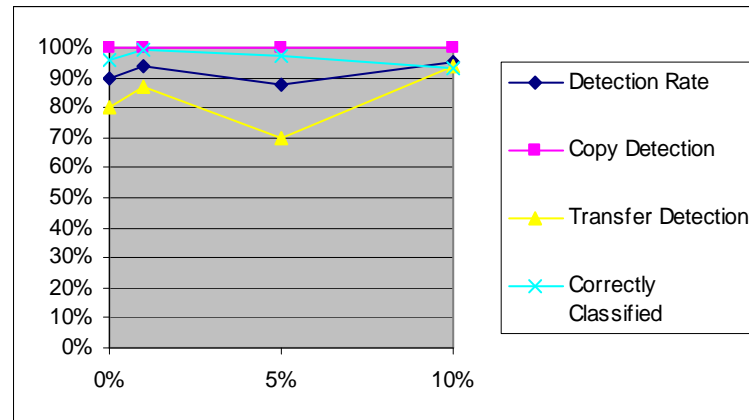

Miss Probability	Counterfeit Detection Rate	Copy Detection Rate	Transfer Detection Rate	Correctly Classified
0%	90%	100%	80%	96%
1%	94%	100%	87%	99%
5%	88%	100%	70%	97%
10%	95%	100%	94%	93%

Thank you!